

PRIVATE.
STRICTLY PROPRIETARY.

GCE

SERVICE MANUAL

HP-3000

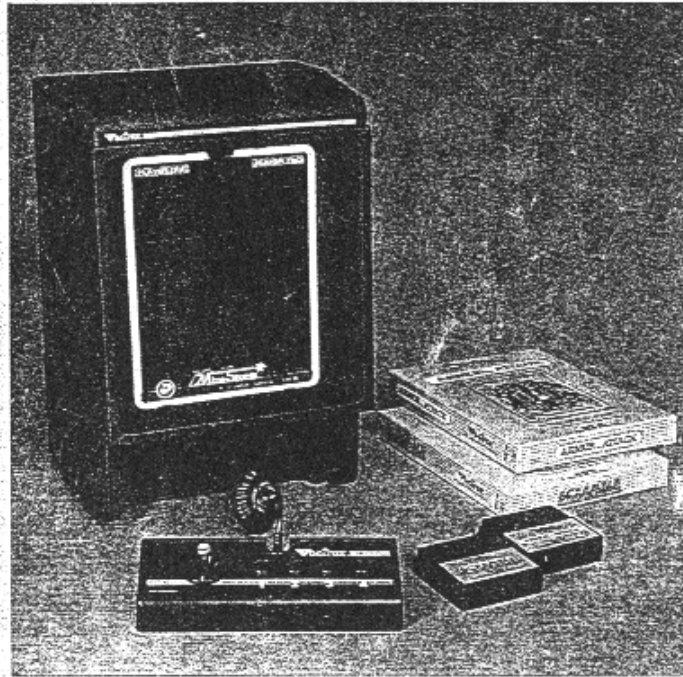

Vectrox™
ARCADE SYSTEM

GENERAL CONSUMER ELECTRONICS, INC.

A MILTON BRADLEY COMPANY

G.C.E. VECTREX SERVICE MANUAL

TABLE OF CONTENTS

I.	SPECIFICATIONS	1
II.	OPERATING INSTRUCTIONS	2
III.	MAINTENANCE AND SAFETY TIPS	7
IV.	TV AND RADIO INTERFERENCE	7
V.	CIRCUIT DESCRIPTION	8
VI.	DISASSEMBLY	11
	A. Back Cover Removal	11
	B. Power Board Removal	11
	C. Logic Board Removal	11
	D. Power Transformer Removal	11
	E. Speaker Removal	12
VII.	LOGIC BOARD ADJUSTMENTS	12
	Logic Board Component Layout	13
VIII.	POWER BOARD ADJUSTMENTS	15
	Power Board Component Layout	14
IX.	CRT/YOKE REMOVAL AND SET-UP	16
X.	HAND CONTROL DISASSEMBLY	16
	Hand Control Schematic	17
XI.	TEST CARTRIDGE PROCEDURE	18
XII.	PARTS LIST	22
XIII.	BLOCK DIAGRAM	29
XIV.	POWER BOARD SCHEMATIC	30
XV.	LOGIC BOARD SCHEMATIC	31
XVI.	PACKAGING	32

I. SPECIFICATIONS

The VECTREX is a self-contained, microprocessor based, Vector Display, portable home video game arcade with external game cartridge program capability.

MPU	68A09	8K X 8 BIT DATA — 16 BIT ADDRESS	
INTERNAL ROM	2363	8K X 8 BIT	<u>PLEASE NOTE:</u>
INTERNAL ^{RAM} ROM	2114 (2)	1K X 4 BIT (ea.)	INTERNAL ROM 2114 (2) should read:
EXTERNAL ROM	(GAME CARTRIDGE)	8K X 8 BIT CAPABILITY	INTERNAL RAM 2114 (2)

CRT: SAMSUNG 240RB40 90 DEG. DEF. B&W VECTOR DEFLECTION

12 EXTERNAL GAME CARTRIDGES CURRENTLY
1 RESIDENT GAME

Second Controller available as an accessory

Game Cartridges include a screen overlay.

120V AC — 60Hz

DIMENSIONS: 9¾ X 11½ X 14½

WEIGHT: 15 Lbs.

II. OPERATING INSTRUCTIONS

UNPACKING

When you remove your Vectrex Arcade System from the box you should have these items:

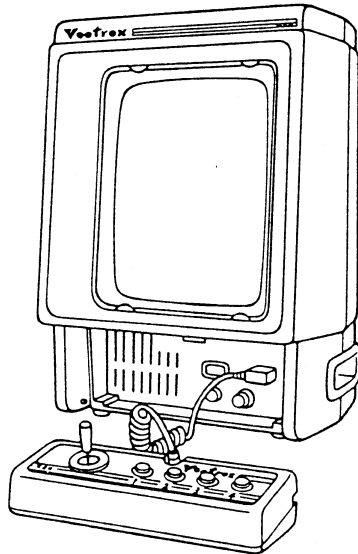

Vectrex Arcade System
Console with Built-in
Control Panel Attached

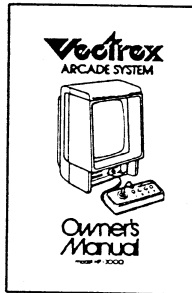

Owner's Manual

Owner's Club Registration Card

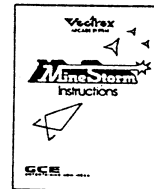
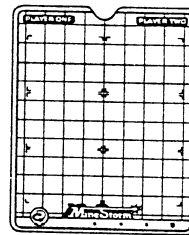
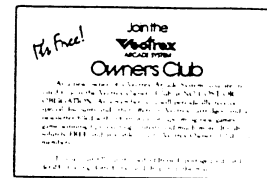

Screen Overlay & Instructions
for Mine Storm™ Game

IMPORTANT: To prevent overheating, never block the ventilation openings on the back or bottom of the console. These openings have been designed to provide proper ventilation during operation and should not be enclosed or covered in any way.

Before inserting the plug, make sure the console switch is OFF. The unit will work in any 120 Volt AC 60 Hz electrical outlet. Using any other power supply will damage the unit. As a special safety feature, the plug is polarized so that it will fit into standard AC outlets in one direction only. If the plug does not slip easily into the outlet, turn it over and insert again.

It's a good idea to save the box and styrofoam inserts in case you ever need to move or ship your Vectrex Arcade System.

SETTING UP

Your Vectrex Arcade System is designed for table-top use. For the most enjoyment, select a location where the screen will be at about eye level when you are playing the games. A sturdy table, desk or shelf is suggested. Do not operate console on a bed, sofa, carpet, etc.

THE CONTROLS

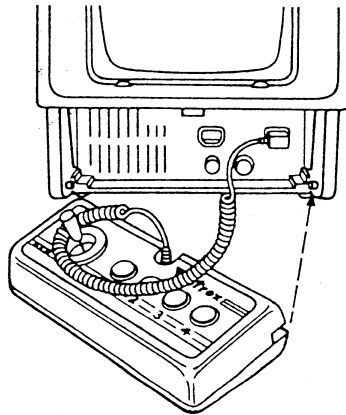

Control Panel Storage

To remove control panel from the storage area at the bottom of the console, press the release tab and the panel will drop down. To return control panel to its storage area:

- Coil the cord **once** around the joystick and then on top of the action buttons.
- Slide the panel onto the tabs at the bottom of the console.
- Flip up the panel until it clicks into place.

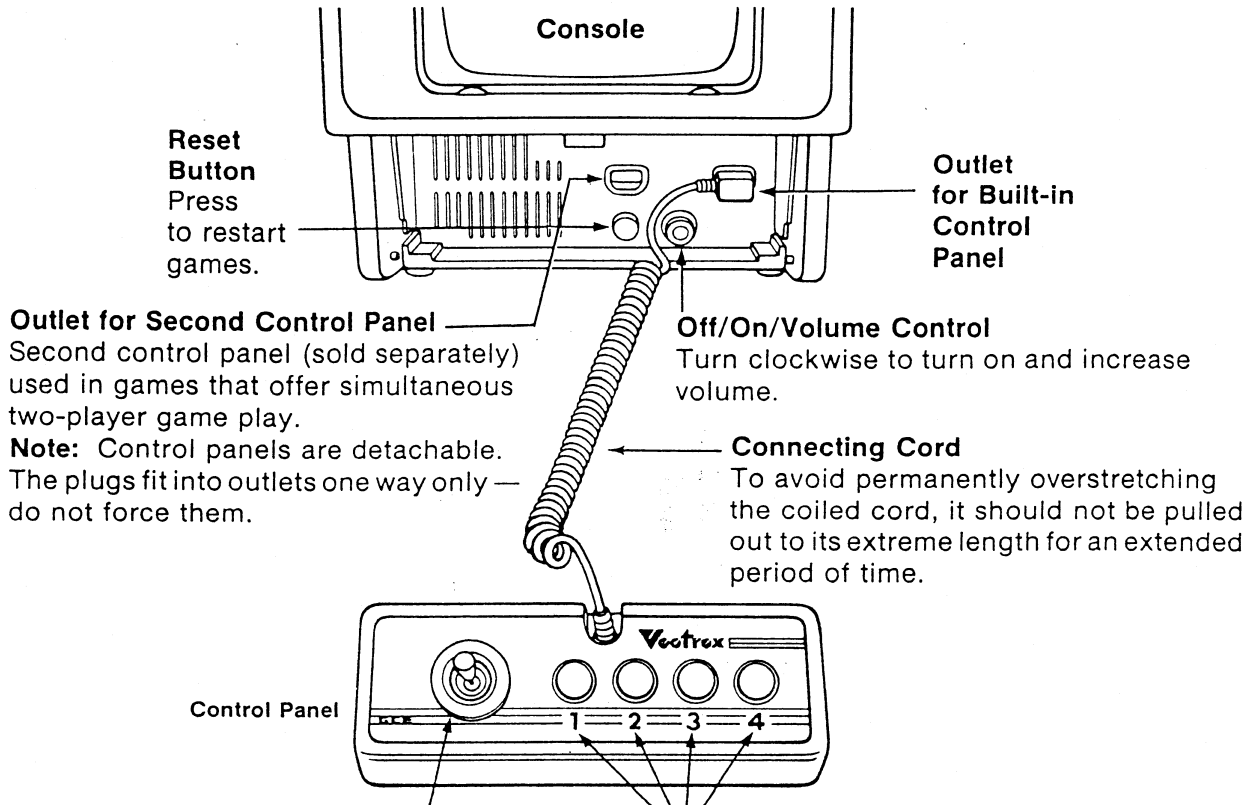

Self-Centering Joystick
Directional control for those games in which direction is a factor. For specific use, refer to instruction manual and screen overlay for each game.

4 Action Buttons
The functions of each button depend on the game cartridge being used. For specific uses, refer to instruction manual and screen overlay for each game.

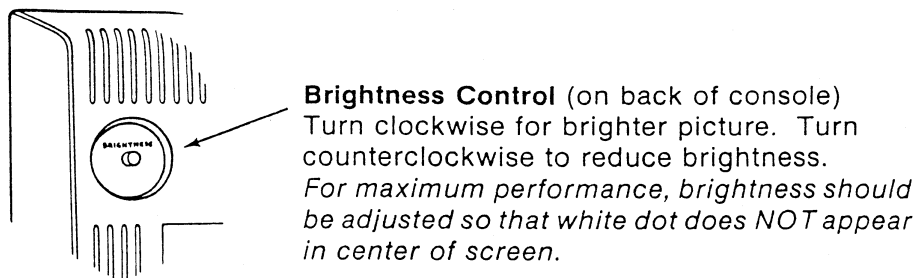

THE CONTROLS

INSERTING AND REMOVING GAME CARTRIDGES

IMPORTANT: TO PROLONG THE LIFE OF YOUR VECTREX ARCADE SYSTEM AND PROTECT THE ELECTRONIC COMPONENTS, THE CONSOLE SHOULD BE TURNED **OFF** WHEN INSERTING AND REMOVING CARTRIDGES.

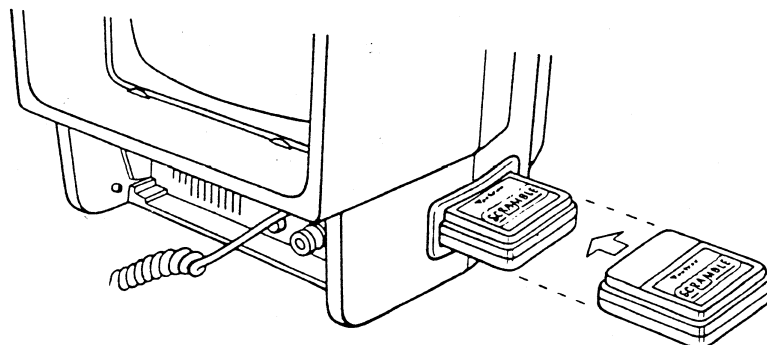

TO INSERT CARTRIDGE

- Make sure the console's power is turned OFF.
- Hold the cartridge with the label side up.
- Insert cartridge carefully into the slot on the right side of the console.
- Be sure the cartridge is firmly inserted to the guideline marked on the cartridge.

TO REMOVE CARTRIDGE

- Make sure the console's power is turned OFF.
- Pull the cartridge straight out of the slot.
- To protect the electronic components, the cartridge should be stored in the original package or other suitable container.

IMPORTANT: Unlike a conventional TV screen, the screen built into the Vectrex console uses an advanced display technology to achieve brilliantly clear images and special visual effects like rotation and zooming. Due to this special display technology, it may appear that the images pulse slightly. **THIS SLIGHT PULSING IS NORMAL AND DOES NOT INDICATE A PROBLEM WITH YOUR CONSOLE.** The screen overlays that are provided with each cartridge have been specially designed to virtually eliminate the slight pulsing.

INSERTING AND REMOVING SCREEN OVERLAYS

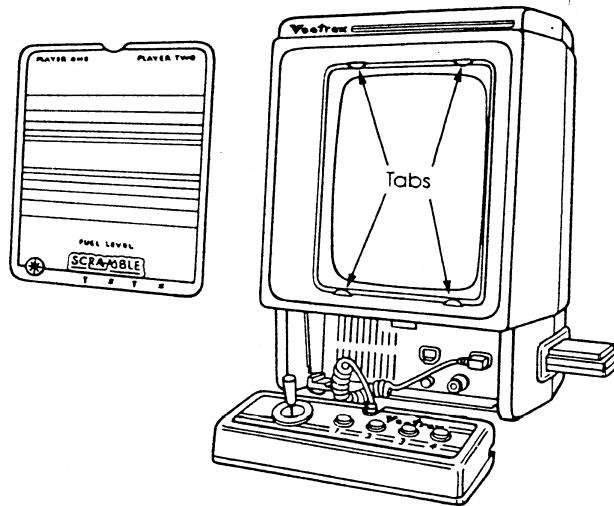

TO INSERT SCREEN OVERLAY

- Slip the bottom of the screen overlay behind the two tabs at the bottom of the screen.
- Push the top of the overlay down slightly using the finger area at the top and press against the tabs at the top until the overlay snaps into place under the tabs.

TO REMOVE SCREEN OVERLAY

- Place your finger in the curved area at the top of the overlay, press down slightly and pull the overlay straight out.
- Store the overlay in the original package or other suitable container.

STARTING GAME PLAY

- Make sure the cartridge and screen overlay are inserted properly.
NOTE: A cartridge is not needed to play Mine Storm, which is the game built into the console.
- Turn the OFF/ON/VOLUME CONTROL to the ON position (clockwise). You will see the Vectrex title for a few seconds, then the name of the game.
- Adjust the volume control to the desired listening level.
- Refer to the individual game instructions for game play details.

III. MAINTENANCE AND SAFETY TIPS

Your Vectrex Arcade System will bring you many years of fun and excitement. In order to keep your Vectrex Arcade System in good working condition, please remember the following:

- Proper ventilation is very important to prevent overheating. Never block the ventilation openings on the back of the console in any way. There are also ventilation slots on the bottom which should not be blocked by placing the console on a bed, sofa, carpet, etc.
- Be careful not to spill liquids on the console, cartridges or control panel and never expose the unit to rain or excessive moisture. If this happens, unplug the console, wipe the outside dry, and then let unit air dry for at least 48 hours before using it again.
- Do not expose the console, cartridges or control panel to excessive or extreme heat. Never place the unit near or over a radiator or heat system.
- Never remove the back cover of the console or drop or push objects through the slots in the back cover. This could expose you to very high voltage.
- If the console is damaged, shock hazard may exist. If damaged or there is a distinct change in performance, immediately unplug the console and have it checked by a GCE Authorized Service Dealer.
- Care should be taken not to drop the console, cartridges or control panel. The console should be lifted using the convenient handle at the upper rear of the console.
- Always turn the power OFF when the unit is not in use and before inserting or removing cartridges. Do not plug into a power source other than 120 Volt AC 60 cycles electrical outlet.
- Clean the screen overlays and the exterior of the console with a soft, slightly dampened cloth. Before cleaning the console, make sure the unit has been turned OFF and the power cord has been disconnected. Never use a household cleaner, cleanser or spray on the overlays or console.

IV. TV AND RADIO INTERFERENCE

The Vectrex console's electronic circuitry generates signals for its own internal use that may cause interference to nearby radio and television receivers. The Vectrex console has been type tested and is in compliance with FCC Rules Part 15 Subpart J for Class B computing devices. However, interference may occur in certain installations. If interference does occur, you should try one or more of the following measures to correct the problem:

- Reorient the TV or radio antenna.
- Move the Vectrex console further from the TV or radio.
- Plug the Vectrex console into a different outlet than the TV or radio.
- Consult your Vectrex dealer or an experienced TV/radio technician for additional suggestions.

A helpful booklet entitled "How to Identify and Resolve Radio-TV Interference Problems" is available from the U.S. Government Printing Office, Washington, D.C. 20402, Stock No. 004-000-00345-4.

V. CIRCUIT DESCRIPTION

As a general description, the HP3000 is a self-contained video game system intended for home use. The system includes its own 9" B&W monitor screen and 3" permanent magnet speaker. Plug-in ROM type cartridges are available offering arcade type video and sound game play. No external TV receiver hookup is needed or provided for. A front panel storable controller allows control over the game via joystick and push button action switches. For two player operation a second controller identical to the single player controller is available as an accessory product. Both controllers attach to the main game console through nine wire coiled telephone style cables. There is a consumer power switch/volume control on the front panel as well as a game reset button. A consumer adjustable brightness control is located on the main console rear housing.

For the technical description which follows, the reader is encouraged to refer to the block diagram and schematic.

The HP3000 is a microprocessor based, vector scan system using a standard 9" black & white CRT as its video display device. The microprocessor (MPU) is the Motorola 68A09 device. The MPU operates at 1.6 MHz from a 6 MHz external Xtal. An internal divide by 4 circuit generates the MPU 1.6 MHz "E" clock signal used in the system. Program memory is stored in the 8K x 8 bit 2363 type ROM. This ROM contains common subroutines, the "executive" or assembler instructions plus one complete game.

Two 1K x 4 bit 2114 type static RAMS provide storage locations for data indicative of locations of objects, game status, and various other information needed by the microprocessor during game operation. Peripheral Interface Adaptor (PIA) Chip, has two 8 bit peripheral ports which interfaces the MPU with peripheral devices and external signals. One of the PIA ports interfaces the General Instrument AY-3-8912 sound-I.O. chip with the MPU and also drives the digital to analog converter chip MC1408. The other PIA port is used as control lines for the sound chip, selector control for the multiplex chip and as a means to read the A/D comparator that's used in the joystick successive approximation circuitry. Sound is either MPU generated directly or by use of the AY-3-8912 sound chip.

The AY-3-8912 sound chip is a programmable sound generator containing 3 tone generators and wave shaping circuitry. This chip also has a single 8 bit I.O. port used to read the status of each of the handcontrollers 4 action switches.

The standard TTL device types 74LS00 and 74LS32 are used as control line decoders to allow the MPU to select the appropriate circuit element to be addressed at any particular time.

The analog processing section includes digital to analog converter (DAC) chip type MC1408, dual 4 channel multiplexer/demultiplexer chip type CD4052, and dual channel op-amps types LF353 and LF347.

DAC chip MC1408 receives an 8 bit word at data terminals D0-D7. DAC output (pin 4) is current source. One section of IC LF353 is used to change this current to a voltage representative of the 8 bit digital word received by the DAC chip. The LF353 voltage is applied to an input of the dual 4 channel multiplexer (MUX) chip CD4052. This same voltage (designated "DAC" on the schematic) is the X-axis drive signal.

The CD4052 MUX chip serves two purposes: it selectively couples, under MPU control, the output of the DAC current/voltage converter to one of 4 places and is used to selectively couple the inputs from the joystick pots to the voltage comparator IC LF353.

The 4 places to which the "DAC" signal is coupled by the MUX are:

- 1) The Y-axis sample and hold IC LF347
- 2) The "O" reference charge capacitor
- 3) The Z-axis (brightness signal) sample and hold IC LF347
- 4) MPU sound resistive matrix

Each of these 4 signals is a voltage value representative of the 8 bit DAC input word for that function.

The joystick pot positions are sensed by a successive approximation process. The MUX chip selects each joystick pot input line and applies it to the plus input of comparator IC LF353. At the same time the MPU generates digital words that are changed to voltages by the DAC and current/voltage converter mentioned previously. These voltages are successfully applied to the comparator's minus input until the MPU generated voltage is equal to the joystick voltage. The MPU then recognizes the digital word representative of the comparison voltage and is able to establish a location for the joystick pot. The present position for each joystick pot is sensed in this manner. The pot position information is updated on a regular basis by the MPU.

Returning to the X and Y axis drive signals, these signals are applied to X,Y integrator IC LF347 negative input pins through series analog switch types 4066B. The "zero" reference signal is applied to the positive inputs of the integrators. There are also analog switches across the integrator IC capacitors. The series analog switches are controlled by MPU signal RAMP and the parallel capacitor switches are controlled by MPU signal Zero 10. RAMP 10 determines when and for how long the X and Y axis voltage levels will be applied to the integrator amps. Zero 10 is used to discharge the X & Y axis integrator caps thus initializing them for the next signal to be integrated.

The outputs of the X,Y axis integrators are coupled through J-FET switches to IC LM379 deflection amplifiers. The LM379 operates as a voltage to current driver, the current through the deflection coils forming the electromagnetic field which deflects the CRT beam. To protect the CRT from spot burn in the event of a loss of deflection, the Y axis drive amplifiers output is detected and a deflection enable/disable signal generated. This signal controls the J-FET switches in series with the X,Y deflection amp inputs to reduce the scan drive signal in the event of a software or hardware failure plus discrete transistor type 2SC1921 operates to bias off the CRT.

Conventional full wave rectification and three terminal regulators are used in the low voltage power supply. A special negative DC source is generated by a voltage double-circuit which is used to supply a 13V to the DAC chip.

The high voltage is generated via an oscillator, drive transistor and flyback type transformer circuitry similar to what is commonly used in small black and white TV receivers.

Judicious use of bypass caps, RF filter chokes, ferrite beads, etc., has been used in the design to control RFI emissions.

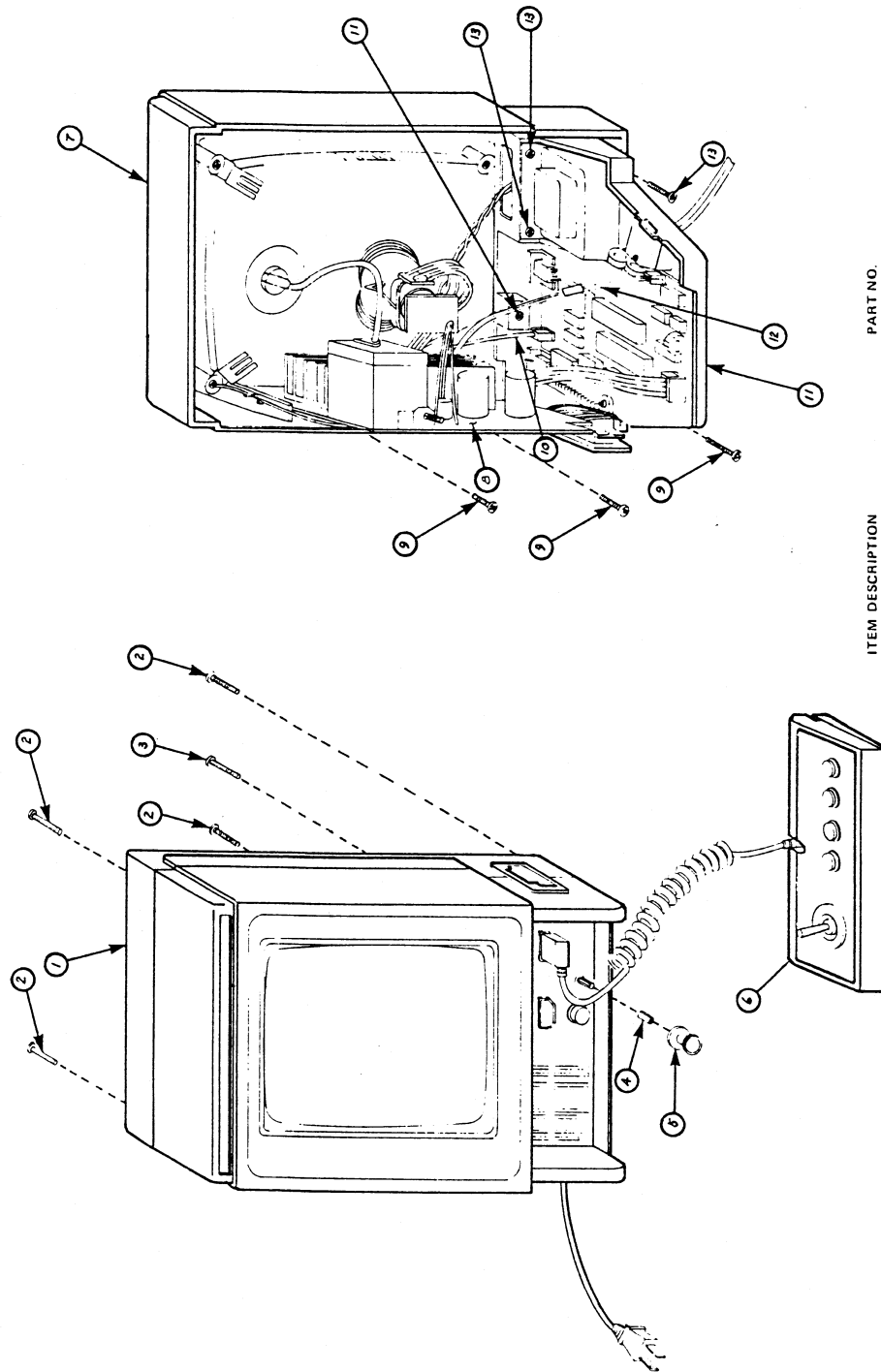

ITEM DESCRIPTION	PART NO.
1 BACK CASE ASSY	100039-1
2 SCREW (BACK TO FRONT CASE ASSY)	130002-2
3 SCREW (BACK TO FRONT CASE ASSY)	130002-3
4 KNOB CLIP	110010-1
5 KNOB, VOLUME - ON/OFF	100023-1
6 CONTROLLER ASSY	990002-1
7 FRONT CASE ASSY	100009-1
8 POWER PCB BRACKET ASSY	100069-1
9 SCREW (PWR BRKT TO FRONT CASE)	130004-4
10 CABLE ASSY - AUDIO	600139-2
11 DIGITAL/ANALOG PCB BRKT ASSY	100069-1
12 CABLE ASSY, VIDEO	6000139-1
13 SCREW (D.A BRKT TO FRONT CASE)	130004-5

VECTREX EXPLODED VIEW

VI. DISASSEMBLY

A. Back Cover Removal

1. Lay the unit on a mat, CRT down.
2. Remove 5 screws from the back cover.
3. Remove the back cover.

B. Power Board Removal

1. Remove all connectors (5) and HV lead from the CRT.
2. Unsolder three leads (2 red, 1 white) from the bottom rear of the board at location EP104, 105 and 106. (Note: Two of these three leads go to the on/off volume control switch, the white lead goes to the power transformer (secondary C.T.)
3. Unsolder the Aquadag ground lead from the top rear of the board.
4. Unsolder ground jumper (braid) between the logic board and power board.
5. Remove two small Phillips head screws from the bottom of the board that secures it to the frame.
6. Slide board back and remove it from the frame.

C. Logic Board Removal

1. Remove all cable connectors from the top of the board (3).
2. Unsolder ground jumper between the logic board and power board at the logic board (left side).
3. Unsolder and remove the 3 power leads at the power board, EP104, 105 and 106. Unsolder 2 of these leads (red) plus 2 from the power transformer on the back of the on/off switch.
4. Remove the logic board mounting frame which includes the speaker, power transformer and reset button by removing retaining screws that hold the frame to the front cover. There are two screws located just above the power transformer bracket that must be removed also.
5. Remove the logic board mounting frame.
6. Unsolder the leads on the reset button.
7. Remove the retaining hardware on the front of the volume control, on/off switch.
8. Remove 4 small Phillips head screws on the top of the logic board that hold the board to the frame. One of the screws holds the plastic game cartridge guide to the logic board. Remove the guide.
9. Remove the logic board.

D. Power Transformer Removal

MAKE SURE A/C CORD IS UNPLUGGED FROM ALL POWER

1. Remove the small screw holding the fuse cover and remove the cover.
2. Remove the screw in the center of the Fuse PCB and remove the PCB.
3. Unsolder the 2 power and two primary leads from the fuse PCB.
4. Unsolder and remove 2 red leads from the on/off switch mounted behind the volume control.
5. Remove the splice on the white lead (secondary C.T.).
6. Remove the two screws holding the power transformer to the frame. Note the ground lead on the right hand screw (as viewed from the rear) has a ground lug on it.

(See Page 12 for Illustration)

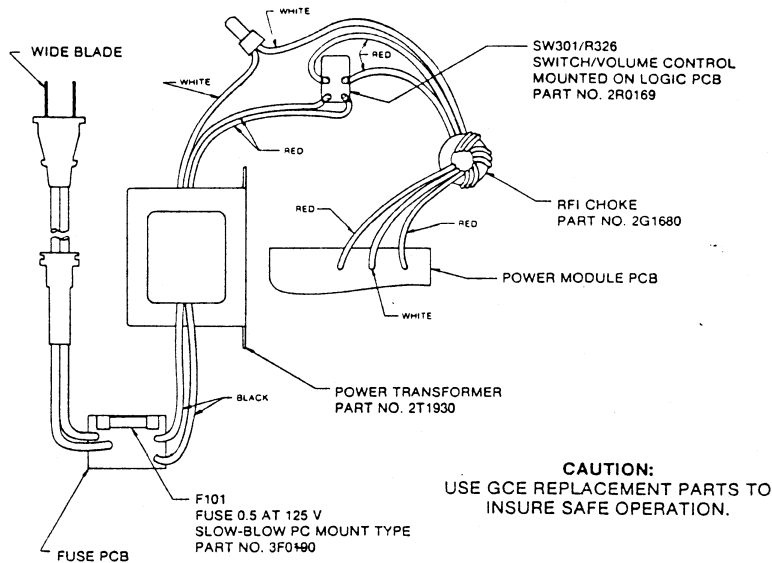

POWER TRANSFORMER WIRING DIAGRAM

E. Speaker Removal

Follow steps 1 thru 7 under "Logic Board Removal."

1. After the frame is out, remove 2 small screws from the top of the speaker grill on the front of the frame. Lift up and out on the speaker grill. The speaker and grill will come out as one.
2. Unsolder speaker leads, note colors on + and - terminals and the position of the terminals in relation to the speaker grill and frame. It must be replaced the same way for lead routing.
3. Loosen retaining clip holding the speaker in.
4. Gently slide the speaker out of the two plastic retaining lips and remove. Rough handling at this point will break these two plastic retaining lips and cause problems in securing another speaker in the assembly.

VII. LOGIC BOARD ADJUSTMENTS

(See Test Cartridge Procedure, Page 18)

After the Logic Board has been replaced and installed in the VECTREX, the following adjustments must be made.

A. Initial Power-up — Install Test Cartridge

1. Plug the unit in and turn it on, volume as required. The CRT should display GCE title page and introductory tune should occur within fifteen (15) seconds of power-up. This should be followed by the test cartridge's title page.

- B. Select "DAC Zero Test." These words will appear on the screen followed by a blank screen, the actual adjustment must be made during this blank screen interval. It will cycle back and forth between the word display and blank screen.

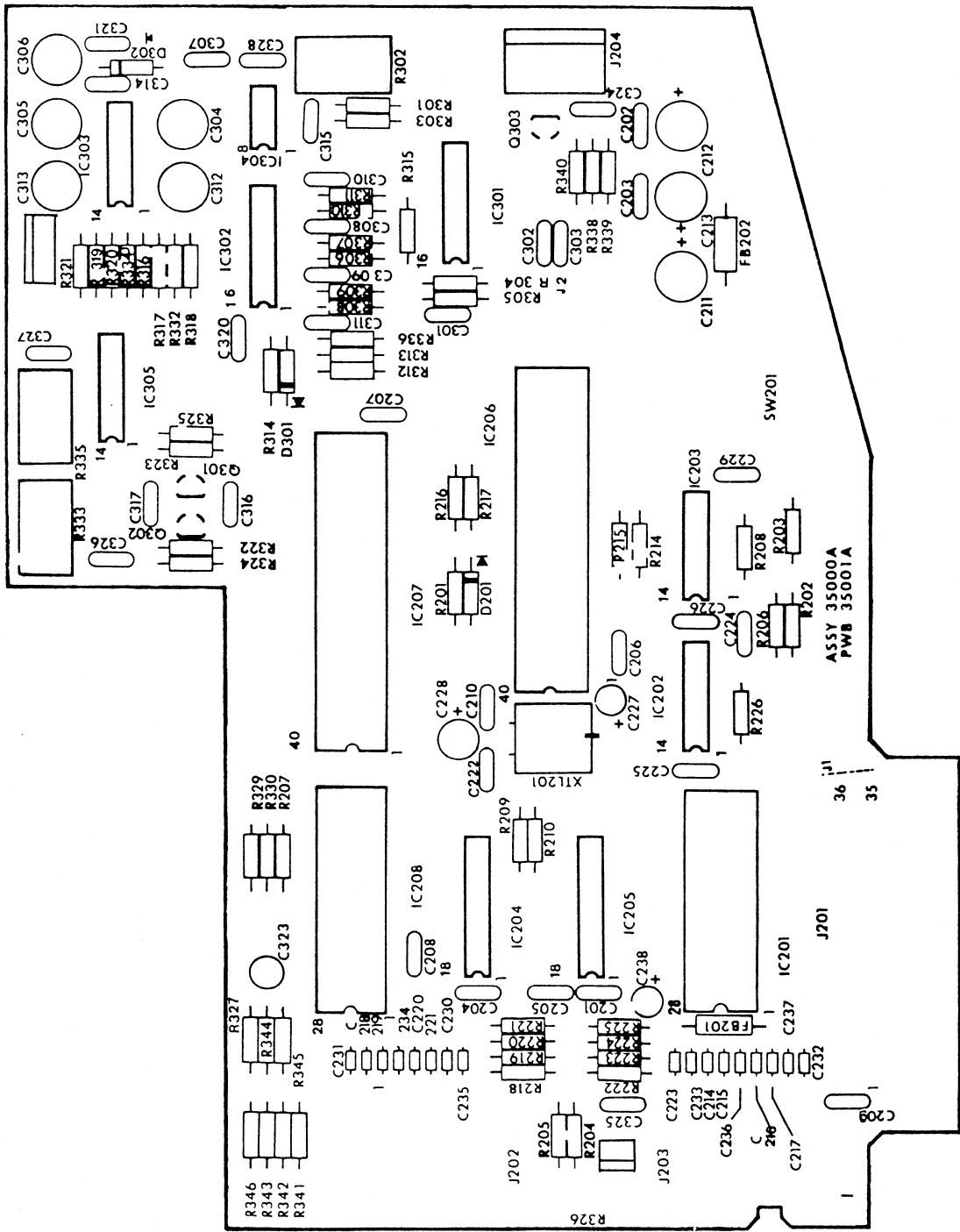

LOGIC BOARD COMPONENT LAYOUT

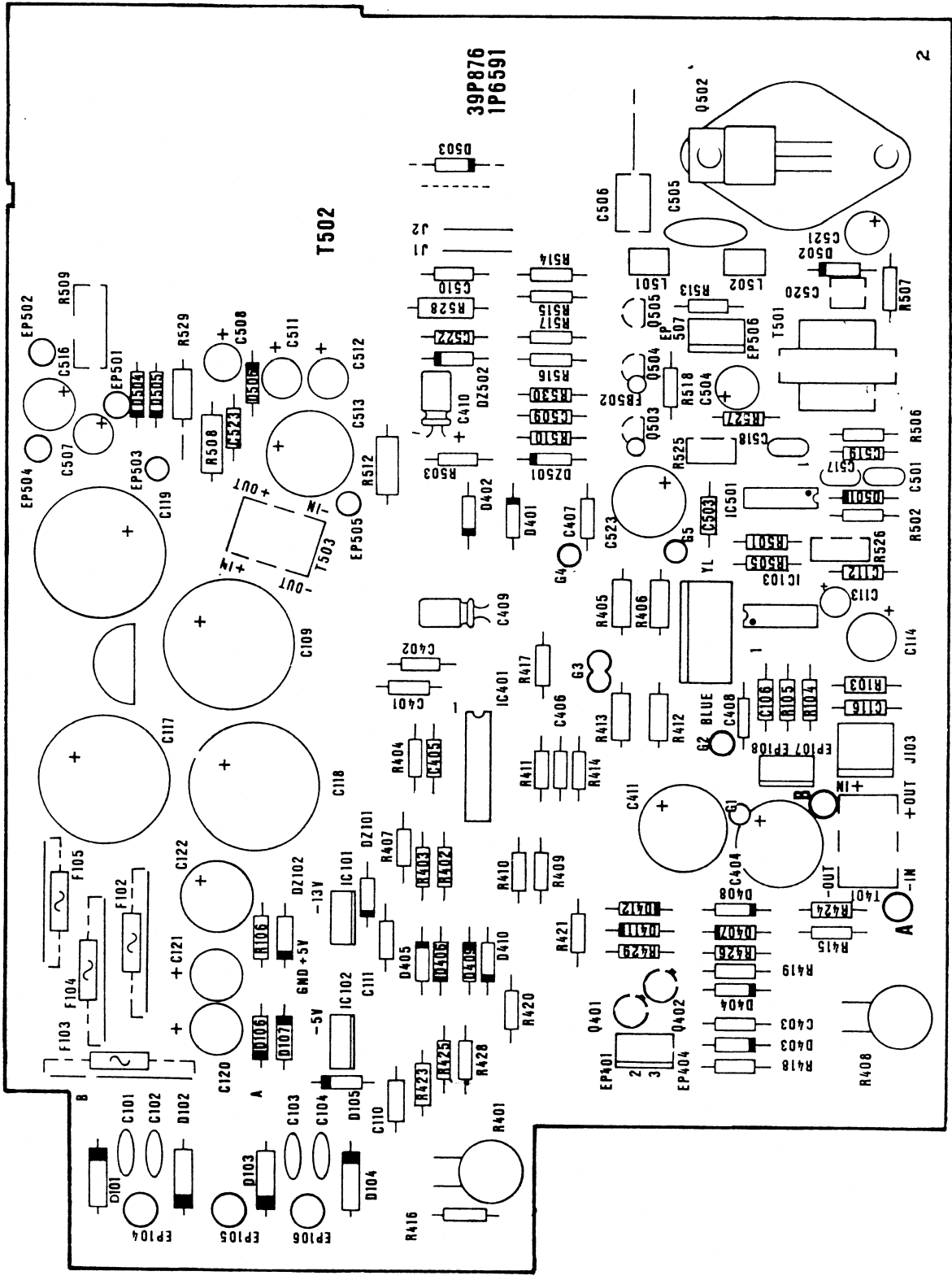

39P876
1P6591

POWER BOARD COMPONENT LAYOUT

Set your scope on "DC" and the 5mv/div scale. Connect the ground lead to ground on the board and connect the probe to pin 1 of IC 304, adjust R302 "DAC OFFSET" POT for OVDC.

After the adjustment is completed, press the reset button.

It may now be necessary to recenter the picture as the DAC zeroing will affect it. Use the centering magnets on the rear of the deflection yoke and the "Linearity Pattern" in the test cartridge to set the centering. UNDER NO CIRCUMSTANCES IS R302 "DAC OFF-SET" TO BE USED TO HELP CENTER THE PICTURE.

C. Integrator Off-Set Test

Select the "Integrator Off-Set" test. Alternately adjust R333 "Y Rate Off-Set" and R335 "X Rate Off-Set" POTs to align the cross bars for intersection at the center of the diamond patterns. The bottom row of diamonds is the most critical and should be used to set these controls — all patterns should be within one (1) line width.

D. Sound Test

Select the "Sound Test." The display will say "CHANNEL A." You should then hear the sound start at a low frequency and increase in frequency. CHANNEL B and CHANNEL C will follow with identical tones.

The next title on the CRT will be "NOISE ALL CHANNELS" and this will be noise (static).

The screen will remain blank and two (2) tones will be heard. This is the "CPU SOUND" check. If any are missing the board must be repaired.

VIII. POWER BOARD ADJUSTMENTS

After installation of the Power Board Assembly make the following checks and, if necessary, adjustments.

- A. Install the Test Cartridge and turn the VECTREX on. The GCE title page on the CRT and the introductory tune should occur within 15 seconds.
- B. Turn the brightness to minimum (R509) and measure the high voltage; it should be 5.8KV+/- 150VDC.
- C. To adjust the high voltage, connect an oscilloscope to T502 pin 7 and set the vertical at 20V/div and the horizontal at 10 usec/div.

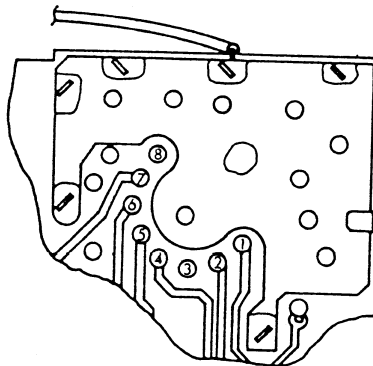

- D. Adjust R526 for minimum ringing in the displayed wave form.
- E. Recheck the H.V. and adjust R525 to get proper reading (5.8KV+/- 105VDC).
- F. Repeat the adjustments of these two controls until proper high voltage and minimum ringing are obtained.
- G. **Deflection Protect Circuit Check (Beam Cut Off)**

Select the "Beam Cut Off" Test. Observe CRT monitor. The pattern will shrink in size, then disappear. In approximately 2-3 seconds, the pattern will reappear at about half-size and continues to increase in size and brightness until it is full-size, then the cycle will repeat. As the pattern decreases, the circuit time constraints prevent the protect switches from activating. When the circuit allows the switches to activate, they will not turn on until the brightness and deflection reach the design limits. This is when the pattern reappears at about half-size.

- H. **Audio Amp. Check**

Select the "Sound Test" and with the volume control set at mid-range, monitor the audio. Sound chip channels A, B, C, and CPU sound test signals must be audible with no noticeable distortion.

IX. CRT/YOKE REMOVAL AND SET-UP

CRT removal, replacement and set-up is the same as most B/W TV tubes in most respects. The primary difference is in the centering technique.

After the CRT/yoke has been installed, do a preliminary centering using the test cartridge linearity pattern for a display and the centering ring magnets on the yoke.

The next step is to set the "DAC ZERO" as directed in Paragraph II of the LOGIC BOARD ADJUSTMENTS. After that is completed again recenter, if necessary, with the ring magnets on the yoke.

Adjust vertical and horizontal height so the linear lines are at the top and bottom, left and right edges of the CRT and front cover. Also see R401 and R408.

X. HAND CONTROL DISASSEMBLY

- A. Remove the Hand Controller cord from the port in the Vectrex.
- B. Remove the top inlay by inserting a tool between it and the case (use extreme caution not to injure yourself) and pry up one edge. Discard the tool and pull the inlay off.
- C. Remove the five (5) screws and remove the top cover.
- D. The P/C Board can be removed by taking out the screen in the center of the P/C Board.
- E. The buttons and pad will then be easily removed.

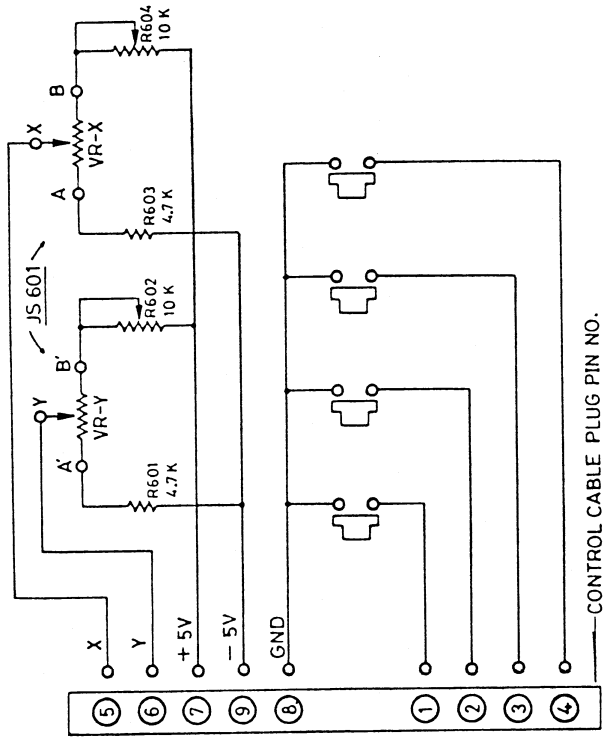
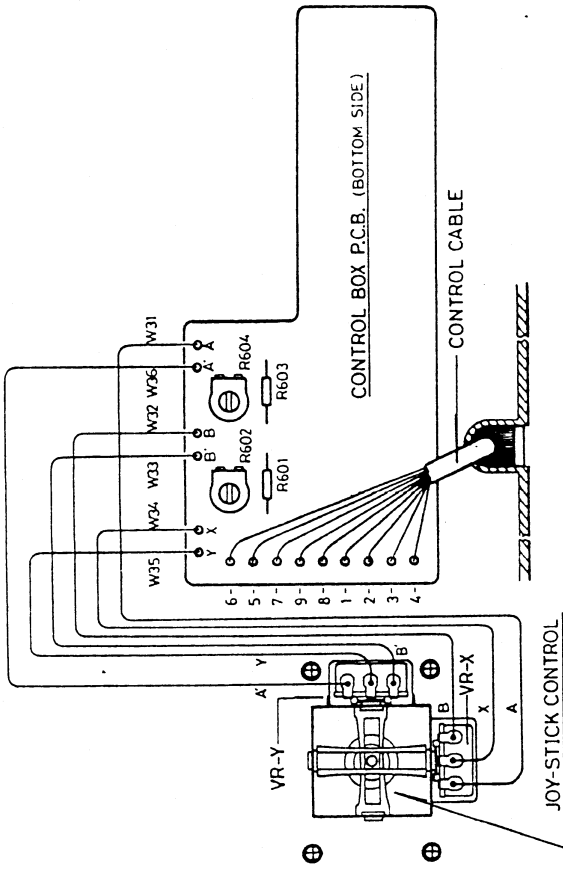

CONTROL BOX CONNECTION

CONTROL CABLE COLOR	TO CONTROL P.C.B. PIN NO.
WHITE	PIN 6
BROWN	PIN 5
GRAY	PIN 7
BLUE	PIN 9
BLACK	PIN 8
GREEN	PIN 1
YELLOW	PIN 2
ORANGE	PIN 3
RED	PIN 4

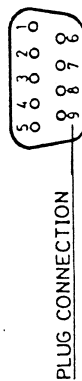

PLUG CONNECTION

HAND CONTROL SCHEMATIC

XI. TEST CARTRIDGE PROCEDURE (REV 4)

Install Test Cartridge

Turn unit on after VECTREX announcement
Title page
then

Linearity Pattern

Check for:

1. Pin Cushion
2. Barreling
3. Keystone
4. Vertical Size
5. Horizontal Size
6. Centering

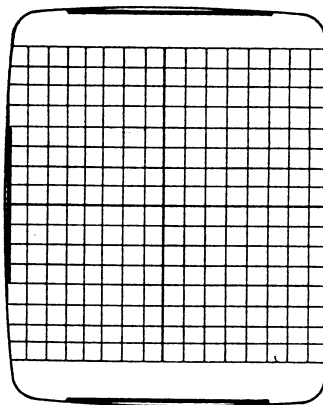

The next test will have the words "Adjust DAC Offset" followed by a blank screen. This is an Oscilloscope Procedure and should be bypassed by pressing Button 3 or 4 **twice** in rapid succession. NOTE: The DAC offset test cannot be escaped from via the controller keys unless the words "ADJUST DAC OFFSET" are on the screen. The words reappear for a short period every 6 seconds. Reset will allow escape at any time.

Good

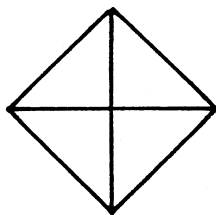

Bad

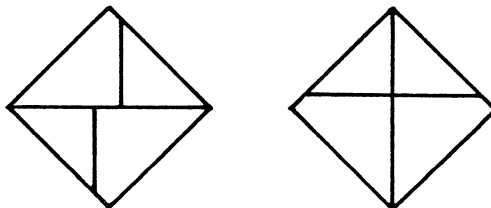

All lines must meet and be continuous.

Press Button 3 or 4:

Wait a few seconds and the checksum will appear and read:

(B796) must appear.

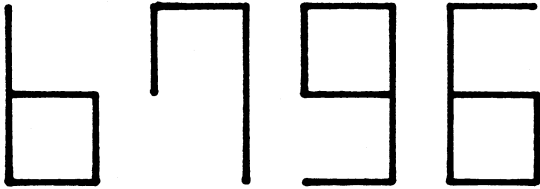

Press Button 3 or 4
BEAM CUT OFF:

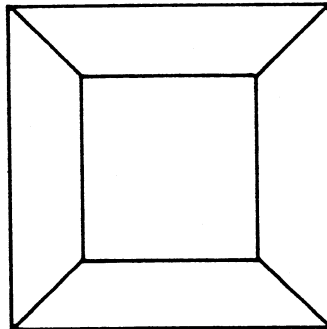

Pattern will decrease in size, then disappear, then reappear in about 2-3 seconds and be about half size and continue to increase until process repeats itself.

Press Button 3 or 4
SOUND TEST:

Words "CHANNEL A" will appear on bottom of the screen should have a one octave tone going from low to high smoothly and continuously.

Words "CHANNEL B" will appear in the middle of the screen with same tone as above.

Words "CHANNEL C" will appear at the top of the screen with the same tone as above.

Words will appear in the center of the screen "NOISE ALL CHANNELS." There will be sound like static for a short duration. Screen will go blank, then you will hear two tones. This is the CPU sound check.

Press either Button 3 or 4:

The word "INTENSITY" will appear with 17 equally spaced lines running horizontally across the screen. The 2nd, 3rd and 4th line from the top should be extinguished; the 5th from the top sits right on top of the word "INTENSITY," and should be visible.

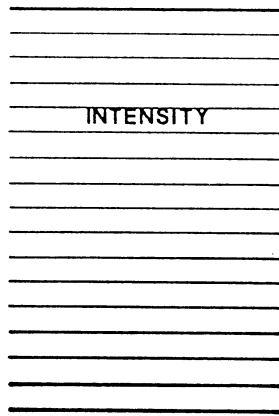

Press Button 3 or 4: **FOCUS TEST**

The focus pattern will appear with symbols.



These symbols should be clearly focused in the center of the screen with minimum unfocus on four (4) corner symbols.

Press Button 3 or 4:

A border of triangles will appear on the screen with (DISTORTION) words in the center, if dissymmetry is apparent, make a note.



Press Button 3 or 4:

A rectangle will appear with the words (DISTORTION 2) in the center.

There are 16 rectangles traced around each other.

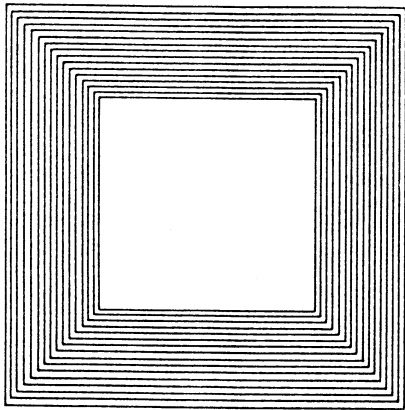

The spacing of each side must be the same for each succeeding rectangle and the overall pattern must be symmetrical.

Press Button 3 or 4.

The key and Joystick pattern will appear:

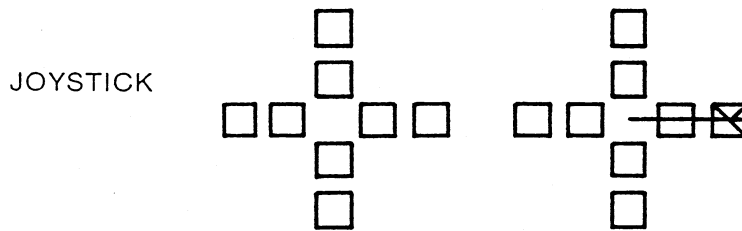
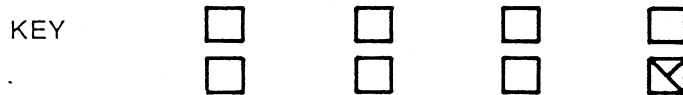

Press Buttons 1 thru 4 consecutively: The proper symbol must appear as each button is pushed in the appropriate square on the top row.

Displace the Joystick 90 degrees to the right slowly. The same symbol as above must appear first in the box closest to the center, then disappear and the outer box must indicate the symbol. There will also be a line that extends from the center of the diagram in the direction the Joystick is pushed. Check all four directions and check that the appropriate box lights up. Also slowly sweep the Joystick 360 degrees at its limits and make sure the line moves smoothly with no dropouts at any point.

Remove the hand control cord from its port and move it to the left port. Repeat the above test.

NOTE: If the left joystick is not plugged in, one of the inner boxes will light because of the 1MEG pull-up resistor internal to the VECTREX.

To escape from the controller test, hold Key 1 down while pressing either Key 3 (to back up to the distortion test) or Key 4 (to advance to the grid pattern).

XII. GENERAL CONSUMER ELECTRONICS PARTS LIST

ITEM	QTY.	DESCRIPTION	PART NO.	CIRCUIT DESIGNATION
------	------	-------------	----------	---------------------

Assembly List

1	1	Console Assembly	4X5280	
2	1	Remote Control Box Assembly	4X5290	
3	1	Logic Board Assembly	4X5450	
4	1	Power Board Assembly	4X5460	
5	1	CRT Board Assembly	4X5470	Beginning From

Power Board Assembly (4X5460)

		Carbon Film Resistor		
1	1	4.7 ohm	3R0091	R507
2	1	10 ohm	3R0151	R103, 506
3	1	39 ohm	3R0231	R530
4	3	100 ohm	3R0321	R417, 514, 527
5	1	47 ohm	3R0241	R505
6	1	150 ohm	3R0341	R515
7	2	220 ohm	3R0381	R513, 5106
8	1	1 K ohm	3R0511	R503
9	4	1.5K ohm	3R0531	R423, 424, 415, 416
10	2	2.2K ohm	3R0561	R501, 510
11	4	3.3K ohm	3R0591	R404, 411, 518, 502
12	2	4.7K ohm	3R0641	R428, 429
13	1	6.8K ohm	3R0681	R104
14	3	10K ohm	3R0711	R425, 426, 516
15	1	820K ohm	3R1131	R530
16	4	47K ohm	3R0861	R105, 420, 421, 517
17	2	3.3M ohm	3R1211	R418, 419
		CARBON FILM RESISTOR +5% 1/2W		
18	1	1K ohm	3R0514	R512
19	2	1.5K ohm	3R0035	R405, 412
				NON-INDUCTIVE
20	1	10K ohm	3R0714	R528
21	1	470K ohm	3R1074	R508
		CARBON FILM RESISTOR +5% 1W		
22	1	3.3 ohm	3R0075	R529
		METAL FILM RESISTOR		
23	2	0.22 ohm +10% 1W	3R0005	R416, 413
				NON-INDUCTIVE
24	2	3.3K ohm +1% 1/4W	3R0593	R407, 414
25	2	15K ohm +1% 1/4W	3R0743	R402, 409
26	2	1M ohm +1% 1/4W	3R1142	R403, 410

ITEM	QTY.	DESCRIPTION	PART NO.	CIRCUIT DESIGNATION
27	2	2K ohm +10% 1/4W	3R2191	R401, 408 (H-TYPE)
28	1	250K ohm +10% 1/4W	3R2192	R509 (V-TYPE, LINEAR)
29	2	4K ohm +10% 1/8W	3R2200	R525, 526 (V-TYPE)
CERAMIC DISC CAPACITOR +80 -20%				
30	1	0.01uF 500V	3C0640	C505
31	4	0.0047uF 500V	3C0621	C101-104
32	2	220pF 50V	3C2151	C106, 510
MULTILAYER CERAMIC CAPACITOR				
33	15	0.1uF +20% 50V	3C0865	C110, 111, 112, 116, 401, 402, 403, 405, 406, 407, 408, 503, 509, 519, 522
ALUMINUM ELECTROLYTIC CAPACITOR (+80 -20%)				
34	1	0.47uF 50V	3E0035	C410
35	1	0.47uF 50V	3E0036	C409
36	1	3.3uF 50V	3E0060	C516 (S.V.)
37	1	4.7uF 100V	3E0076	C507 (S.V.)
38	1	10uF 16V	3E0097	C113
39	2	15uF 63V	3E0100	C508 (S.V.)
40	2	22uF 16V	3E0102	C511, 512
41	3	47uF 16V	3E0132	C504, 521, 120
42	1	47uF 25V	3E0129	C121
43	1	220uF 16V	3E0152	C114 (S.V.)
44	1	220uF 25V	3E0153	C122 (S.V.)
45	1	470uF 16V	3E0172	C523 (S.V.)
46	3	1000uF 25V	3E0183	C404, 411, 513 (S.V.)
47	2	4700uF 25V	3E0262	C109, 119 (S.V.)
48	2	10000uF 25V	3E0266	C117, 118 (S.V.)
POLYPROPYLENE CAPACITOR				
49	1	0.082uF +/- 10% 400V	3E0731	C506
MYLAR CAPACITOR (50V Min.)				
50	1	0.0022uF +/- 10%	3C1031	C501
51	1	0.0033uF +/- 10%	3C1041	C517
52	2	0.033uF +/- 10%	3C1201	C518, 520
RECTIFIER				
53	1	1N4001 1A 50 PIV	3M1032	D105
54	4	1N5624 3A 100 PIV	3M4550	D101, 102, 103, 104
55	3	1N4005 1A 600 PIV	3M4570	D503, 504, 506
ZENER DIODE				
56	2	6.2V +/- 5% 1N753 400mW	3M1240	DZ501, 502
57	1	6.2V +/- 10% 5W 1N5341	3M1244	DZ101

ITEM	QTY.	DESCRIPTION	PART NO.	CIRCUIT DESIGNATION
58	1	13V +/- 1V @ 10mA 400mW	3M1322	DZ102
59	16	1N4148 Signal Diode	3M1051	D405 thru 412 D106, 107 thru D404 D501, 502
60	1	MR 852 Damper Diode	3M4560	D503
		TRANSISTOR		
61	1	2N3904 NPN	3M3260	Q505
62	1	2N3905 PNP	3M3270	Q504
63	1	BU407 NPN	3M3280	Q502
64	1	2SC1921 NPN	3M3290	Q503
		N-CHANNEL JFET		
65	2	2N3824	3M3300	Q401, 402
66	1	DRIVING X'FORMER (EI-19)	2T1420	T501
67	1	LM379 Dual 6W AMP.	1V2970	IC401
68	1	LM386-3 1.5W AMP.	1V2980	IC103
69	1	LM555 Timer	1V1840	IC501
		VOLTAGE REGULATOR		
70	1	7805 +5V OR LM340T +5V	1V2533 1V6602	IC101
71	1	79005 - 5V	1V2532	IC102
72	1	Power Board (Solder Plate)	1P6592	PCB
73	2	Ferrite Cylinder 03 x 6mm	2B0530	FB501, 502
		R.F. Choke Coil (1/4" I.D. Air Core)		
74	2	7 Turn AWG#24 0.3 uH 0.8A	2G2030	L501, 502
75	2	Full Turn 2 x 1.5 mH 3A	2G1690	T401, 503
76	1	Flyback Transformer	2T1410	T502
77	1	CRT Board Assembly	4X5440	
78	1	Video Cable Assembly	4Y0820	
79	1	Audio Cable Assembly	4Y0830	
80	1	DC Power Cable Assembly	4Y0790	
		MOLEX WAFER		
81	1	2 PIN (09-74-1021)	2J0390	
82	1	4 PIN (09-74-1041)	2J0360	
83	2	2 PIN (22-04-1021)	2J0430	
84	1	4 PIN (22-04-1041)	2J0380	
85	2	Insulation Spacer (for LM379)	4D4960	
86	2	Insulation Spacer (for Regulators)	4D4970	

*Critical Safety Component — Must Use Exact Replacement

ITEM	QTY.	DESCRIPTION	PART NO.	CIRCUIT DESIGNATION
87	4	Heat Sink Supporter	4T8110	
88	1	Insulation Sheet (for LM79M05)	4K1161	
89	1	Insulation Sheet (for LM379)	4K1850	
90	AR	Silicone Compound (Dow Corning 340)		
91	1	30W Heat Sink	4T8090	
92	1	Shield Can	4T8070	
93	1	Shield Can Cover	4T8080	
94	1	Grommet	4D4840	
95	6	M3.0 x 16 x 0.5P CR-P/H	6S2440	
96	2	4-4ONC-2B x 14 P/H	6S3091	
97	2	M2.6 x 6 x 0.45 P CR-P/H	6S1130	
98	6	Spring Washer 05.5 x 3.2 x 0.7	6W0020	
99	2	Spring Washer 02.8	6W0960	
100	6	03.2 x 06 x 0.6T	6W0190	
101	2	02.8 x 07 x 0.5 Plain Washer	6W0310	
102	1	M3.0 x 6 x 0.5P CR-P/H		
103	1	M3.0 x 0.5P Nut	6N0050	
104	1	03.2 Spring Washer		
105	6	Heat Sink Supporter	4T8110	
Cable Assemblies				
1		DC Power Cable	4Y0790	
2		Deflection Coil Cable	4Y0800	
3		Speaker Cable	4Y0810	
4		Video Cable	4Y0820	
5		Audio Cable	4Y0830	
6		Ferrite Toroid Assembly	2G1680	
Logic Board Assembly (4X5450)				
Carbon Film Resistor +/- 5% 1/4W				
1	5	33 ohm	3R0221	R214-217, 226
2	2	75 ohm	3R0281	R318, 321
3	1	100 ohm	3R0321	R208
4	2	220 ohm	3R0381	R317, 320
5	12	680 ohm	3R0481	R218-225, 306, 308, 310, 312
6	3	1K ohm	3R0511	R341, 343
7	2	2.2K ohm	3R0561	R314, 315
8	11	3.3K ohm	3R0591	R202-207, 209, 322, 324, 210, 330
9	2	4.7K ohm	3R0641	R338, 339
10	1	6.8K ohm	3R0681	R329
11	1	10K ohm	3R0711	R340
12	2	15K ohm	3R0741	R323, 325
13	2	22K ohm	3R0771	R201
14	4	33K ohm	3R0821	R327, 344-346
15	4	330K ohm	3R1051	R307, 309, 311, 313
16	1	1M ohm	3R1141	R336
17	2	3.3M ohm	3R1211	R332, 334
Metal Film Resistor +/- 1% 1/4W				
18	3	2.7K ohm	3R0580	R304, 305, 301
19	1	3.6K ohm	3R0610	R303

ITEM	QTY.	DESCRIPTION	PART NO.	CIRCUIT DESIGNATION
20	2	10K ohm	3R0713	R316, 319
		Semi-Fixed Resistor (Vert. Type) 016MM		
21	3	10K ohm +/- 10% 1/4W	3R2210	R333, 335, 302
22	1	10K Volume Control W/Rotary SW	2R0169	R326
		Multilayer Ceramic Cap.		
23	13	0.001uF +/- 20% 50V	3C2120	C230-233, 214-221, 229
24	28	0.1uF +/- 20% 50V	3C0865	C201-209, 223-226, 234-237, 301, 302, 316, 317, 320, 321, 326-328, 324, 314
		Tantalum Capacitor		
25	1	22uF +/- 10% 16V	3C1640	C227
26	1	10uF +/- 10% 16V	3C1543	C238
		Aluminum Capacitor +80 -20%		
27	1	4.7uF 16V	3E0072	C323
28	1	220uF 16V	3E0152	C211
29	1	10uF 16V	3E0097	C228
30	2	100uF 16V	3E0142	C212, 213
		Ceramic Disc Capacitor		
31	2	20pF +/- 1pF 50V	3C0160	C210, 222
32	2	47pF +/- 20% 50V	3C0284	C303, 315
33	1	220pF +80 -20% 50V	3C2151	C325
		Polystyrene Capacitor		
34	5	0.01uF +/- 5% 50V	3E0710	C304-306, 312, 313
35	1	Logic Board (Solder Plate)	1P6600	PCB
		Mylar Capacitor (50V Min.)		
36	5	0.001uf +/- 10%	3C1012	C307-311
37	3	1N4148 Signal Diode	3M1051	D201, 301, 302
		Transistor		
38	1	2N3904 NPN	3M3260	Q303
39	2	2N3905 PNP	3M3270	Q301, 302
		Crystal (Without Coating)		
40	1	6.0000 MHz Crystal	3K0162	X'TAL 201
41	2	40 PIN I.C. Socket	2J0190	
42	2	28 PIN I.C. Socket	2J0010	
43	2	18 PIN I.C. Socket	2J0200	
44	2	16 PIN I.C. Socket	2J0011	
45	4	14 PIN I.C. Socket	2J0260	
46	1	8 PIN I.C. Socket	2J0440	

ITEM	QTY.	DESCRIPTION	PART NO.	CIRCUIT DESIGNATION
		Molex Wafers		
47	1	4 PIN (09-74-1041)	2J0360	J204
48	1	2 PIN (22-04-1021)	2J0430	J302
49	1	4 PIN (22-04-1041)	2J0380	J301
50	1	68A09 CPU	1V2951	IC206
51	1	6522 PIA	1V2952	IC207
52	2	2114 RAM	1V2953	IC204, 205
53	1	2363 8K x 8 ROM	1V6601	IC201
54	1	LF347 Biffet Quad. AMP or TL084	1V2960 1V2961	IC303
55	1	LF353 Biffet Quad. OP-AMP or TL082	1V2962 1V2963	IC304
56	1	74LS00 Quad. 2/IN NAND	1V0279	IC202
57	1	74LS32 Quad. 2/IN OR	1V0301	IC203
	1	AY-3-8912 Sound Gen.	1V2950	IC208
58	1	MC-1408-P8 DAC	1V2900	IC301
59	1	4052B CMOS MUX	1V2901	IC302
60	1	4066B BI-SWITCH	1V2964	IC305
61	1	36 PIN Edge Connector	2J0300	J201
62	2	9 PIN Socket (Control Cable)	2J0270	
63	2	Ferrite Tube 06 x 7.6mm	2B0540	FB201, 202
		Remote Control Box Assembly (4X5290)		
1	1	Front Case	4D440	
2	1	Bottom Case	4D4450	
3	4	Keybutton	4D4480	
4	1	Joystick Lever	4T7890	
5	1	Joystick Bracket	4B0872	
6	1	Joystick 10Kx2	2R0171	
7	1	Conductive Rubber	4D4590	
8	1	Key Board (106x44) MM	1P6571	
9	2	Carbon Film Resistor 4.7K +/- 5% 1/4W	3R0641	R601, 603
10	2	Semi-Fixed Resistor (Horiz. Type) 10K ohm +/- 10% 1/8W Plastic Element	3R2180	R602, 604
11	1	9 Conductor Control Cable	3W2890	
		Console Assembly (4X5280)		
1	1	Front Case Sub Assy	4Y0760	
2	1	Back Case Sub Assy	4Y0770	
3	1	Cartridge Insert	4D4510	
4	1	Volume Control Knob	4D4500	
5	1	Remote Box Catch	4D4550	
6	1	Logic Board Bracket	4D4520	

ITEM	QTY.	DESCRIPTION	PART NO.	CIRCUIT DESIGNATION
7	1	Power Board Bracket	4D4540	
8	1	Speaker Frame	4D4530	
9	2	Fixing Stud	4D4570	
10	4	Rubber Stand (Console)	4D4600	
11	4	Rubber Stand Spacer	4T8030	
12	4	Rubber – CRT	4D4580	
13	1	Knob Clip	4T3660	
14	2	Grounding Plate, CRT	4T7861	
15	1	Board Compartment Cover	4F1520	
16	1	Speaker Clamp	4T7850	
17	1	Heat Sink	4T7960	
18	1	Toroid Cover	4F1600	
19	1	CRT 240RB4	1V4500	
20	1	Deflection Yoke (450uH)	2G17002	
21	1	Power Transformer (EI-66)	2T1930	T101
22	1	Ferrite Toroid Assembly	2G1680	T102
23	1	Close End Connector	5C0370	
24	1	Speaker 3" 8 ohm 1W	2L0101	SPKR 101
25	1	Reset Switch	2S0360	MS-029
26	1	Power Cord SPT-2	3W1690	
27	1	Fuse 0.5A T-125V	3E0190	
28	1	Fuse P.C.B.	1P6582	
29	1	Deflection Coil Cable Assembly	4Y0800	
30	1	Speaker Cable Assembly	4Y0810	
31	1	Connecting Patch (LEG)	4T2390	
CRT Board Assembly (4X5440)				
Carbon Film Resistor +/- 5% 1/2W				
1	3	1.5K ohm	3R0534	R522-524
2	1	100K ohm	3R0954	R519
3	2	220K ohm	3R1004	R520, 521
Ceramic Capacitor +80 -10%				
4	2	0.01uF 1 KV	3C0641	R514, 515
5	3	Spark Gap 1.5 KV	3F0180	SG501-503
6	1	CRT P.C.B.	1P4950	
AWG #22 Strand Wire uL 1007				
7	1	190mm Blue	3W7476	From CRT to Pwr Bd
8	1	190mm Gray	3W7478	From CRT to Pwr Bd
9	1	190mm Black	3W7470	From CRT to Pwr Bd
10	1	190mm Brown	3W7471	From CRT to Pwr Bd
11	1	7 PIN CRT Socket	2J0500	SMK P501 P.C. MOUNT

*Critical Safety Component — Must Use Exact Replacement

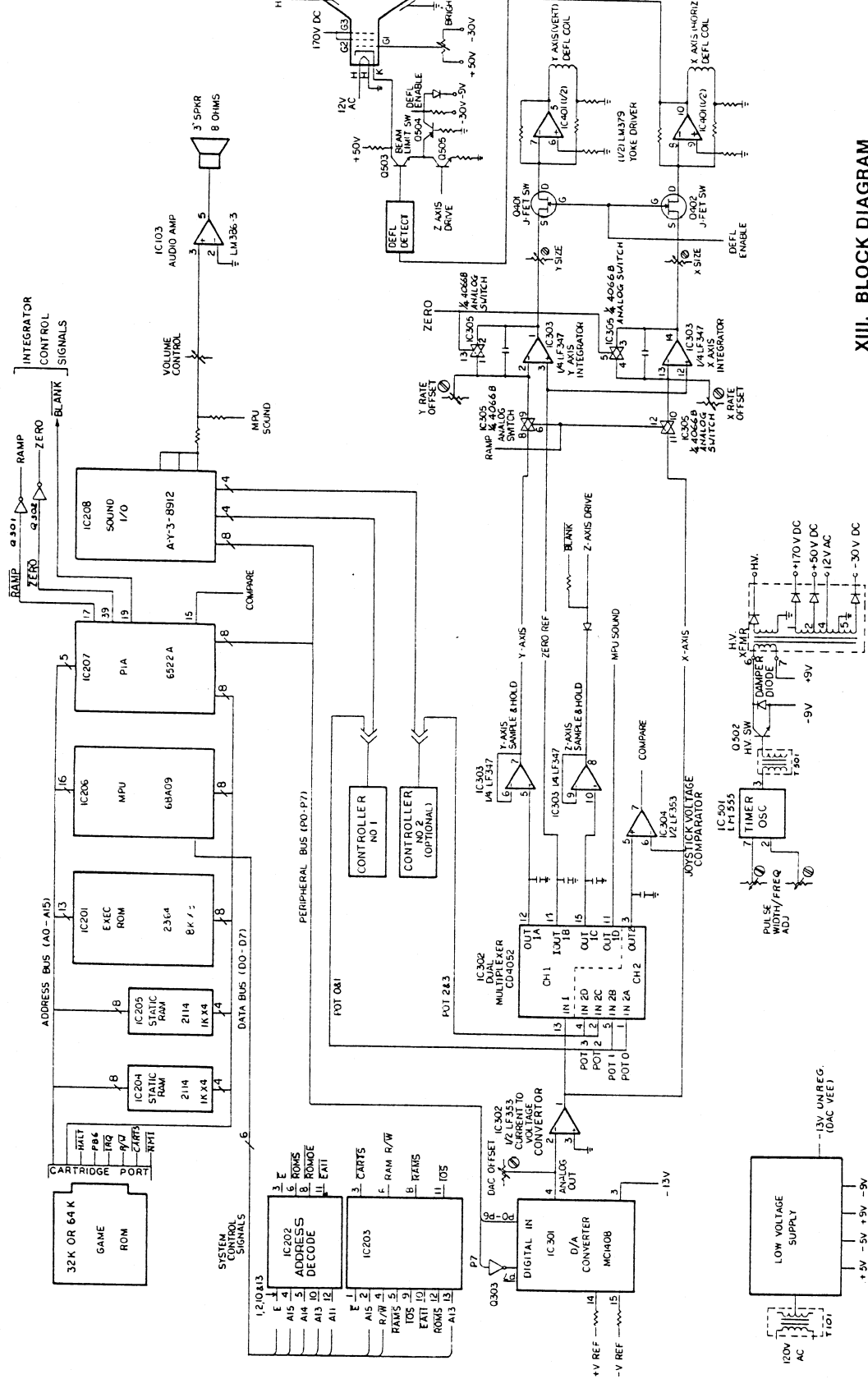

XIII. BLOCK DIAGRAM

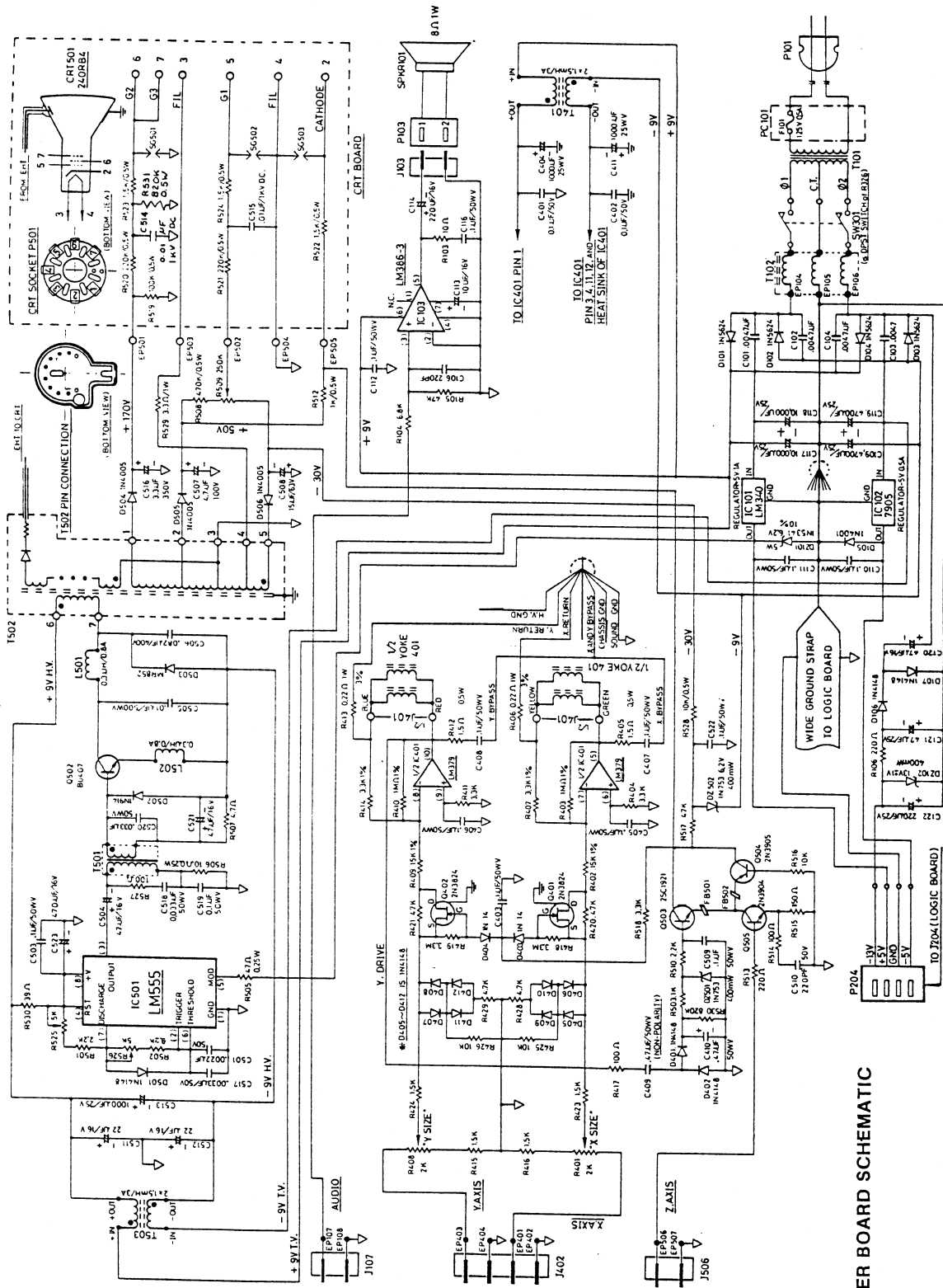

220(36PIN) CARTRIDGE RECEPTACLE

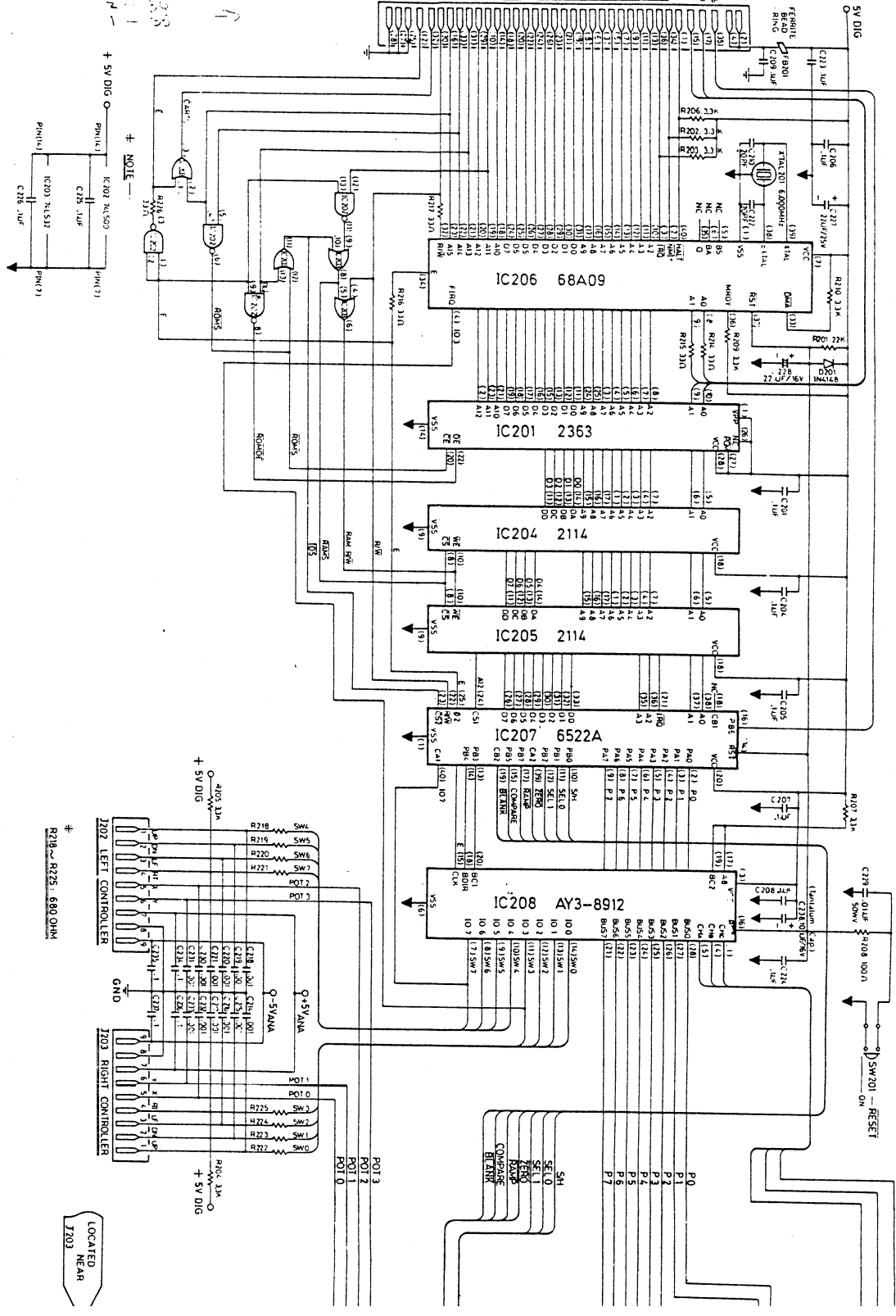

NOTE

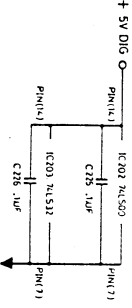

LOCATED NEAR J203

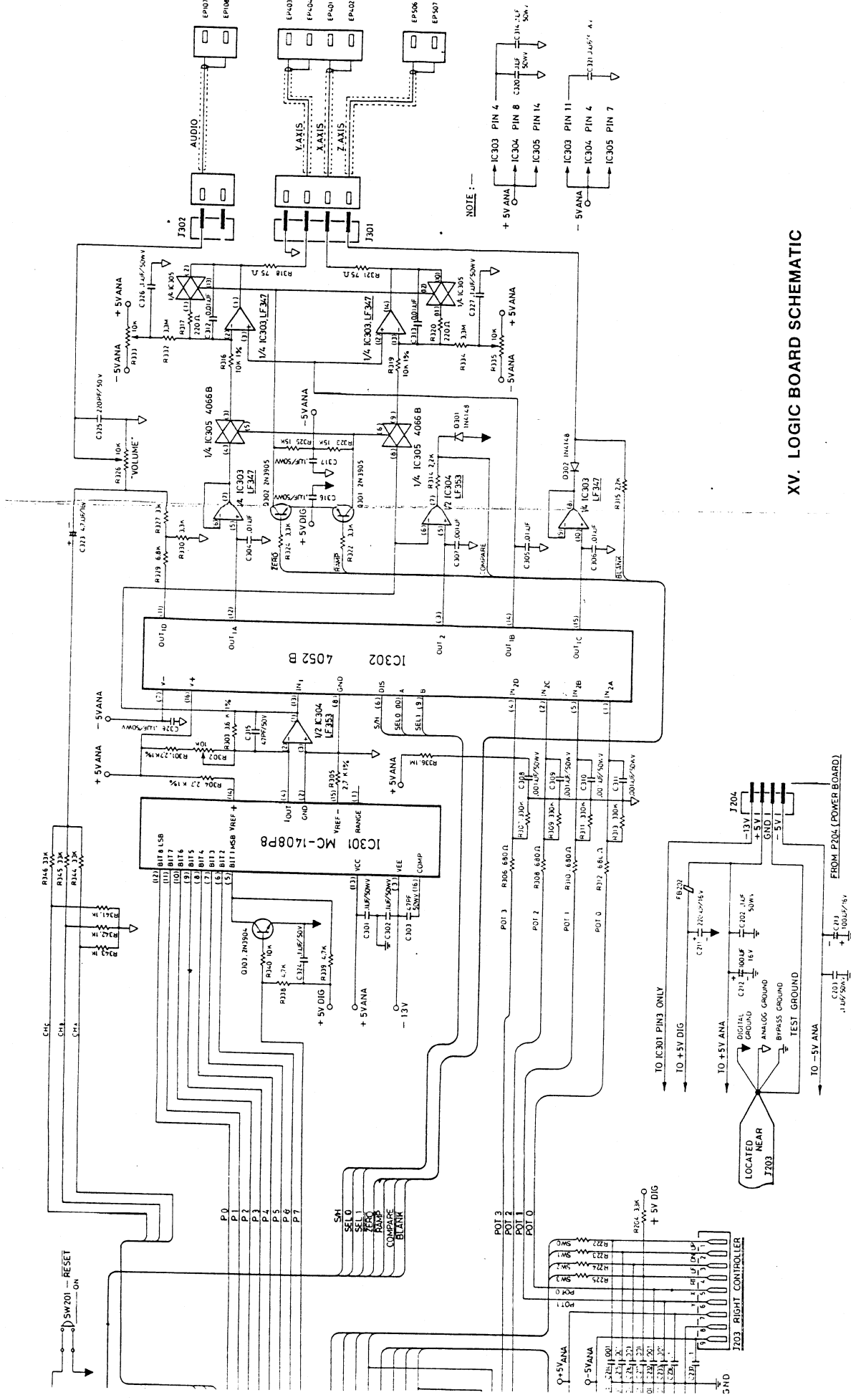

XV. LOGIC BOARD SCHEMATIC

XVI. PACKAGING

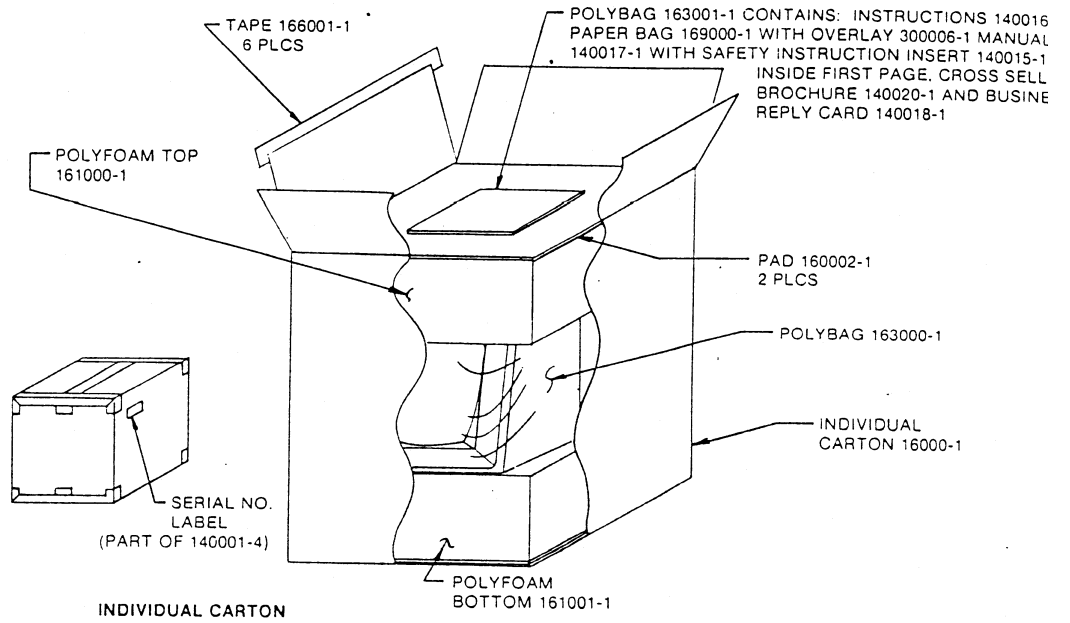

VECTREX PACKAGING ASSEMBLY